

PCM 909560 E

Dimensions

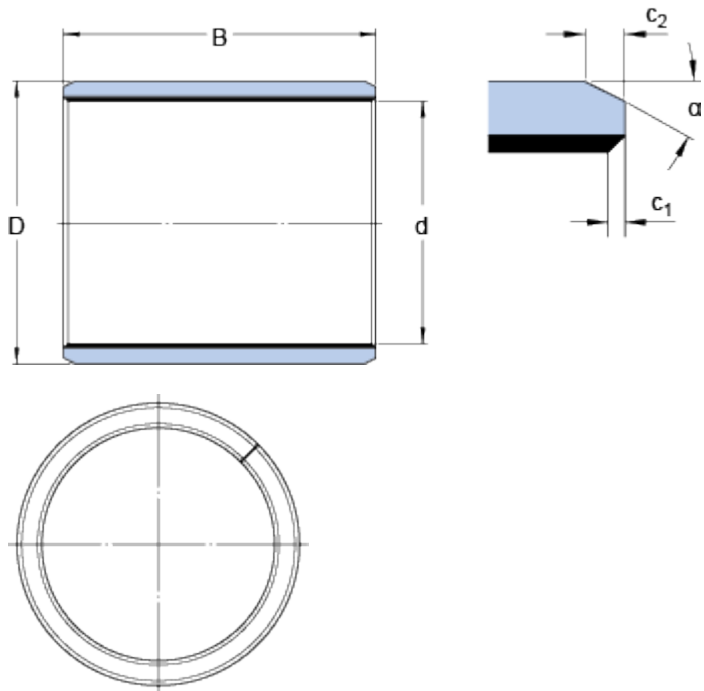

d	90	mm
D	95	mm
B	60	mm
c ₁	min. 0.2	mm
c ₁	max. 1	mm
c ₂	min. 1.2	mm
c ₂	max. 2.4	mm
α	±8 20	°

Recommended fits

Tolerance shaft	h8
Tolerance housing	H7

Calculation data

Basic dynamic load rating - radial direction	C	425	kN
Basic static load rating - radial direction	C ₀	1320	kN
Specific dynamic load factor	K	80	N/mm ²
Specific static load factor	K ₀	250	N/mm ²
Factor depending on material and bearing type	K _M	480	
Permissible sliding velocity	v	min. 0	m/s
Permissible sliding velocity	v	max. 2	m/s
Coefficient of friction	μ	min. 0.03	
Coefficient of friction	μ	max. 0.25	

Mass

Mass bushing	0.33	kg
--------------	------	----